



# CANISTER T638

30W Large Track Head

3300 lm | 120 V | 30 W

## Product Description

T638 LED track head features a minimalist canister design to meet the functional and the aesthetic requirements for indoor applications. The compact size is unobtrusive. The beam spots has no hot spot or light spill. It is smooth in the center and gradually fades to a soft edge. Glare is minimized with the deep regressed lens. With T638, you can control exactly which areas are bright, as well as which areas are dim.

## Specification

- Voltage: 120 V
- Wattage: 30W
- Dimming: TRIAC/ELV
- Tilt: 90°
- Rotate: 350°
- Cold forged aluminum body heat sink
- Powder coated finish
- PMMA TIR precision lens
- Compatibility: H/J/L/G
- Source lumen: 3300lm@30W
- Source lumens per watt: 110
- Delivered lumen: 2400lm@30W
- Lumen Maintenance: 70% @60,000 hrs
- Approved Location: IP20, Dry
- Certification: cETLus
- Five year limited warranty, Consult website for detail: [vyvydlighting.ca/legal](http://vyvydlighting.ca/legal)

Project Name :
Location :
Quantity :
Note :



## Order Information Example: T638-30-30K-FD-B-E

Series	Power	Light Source	Beam Angle	Trim Colour	Dimming	Accessories
<b>T638</b>						
Integrated LED Track Fixture	30 - 30 W	<b>27K</b> - 2700K, Ra>90 <b>30K</b> - 3000K, Ra>90 <b>35K</b> - 3500K, Ra>90 <b>40K</b> - 4000K, Ra>90 <b>50K</b> - 5000K, Ra>90	<b>NS</b> - Narrow Spot (18°) <b>SP</b> - Spot (24°) <b>FD</b> - Flood (33°) <b>WF</b> - Wide Flood (43°)	<b>B</b> - Black <b>W</b> - White <b>S</b> - Silver	<b>E</b> - TRIAC/ELV	<b>[Blank]</b> - None <b>43HC</b> - Honeycomb Louvre



# CANISTER T638 30W Large Track Head

## Dimensions

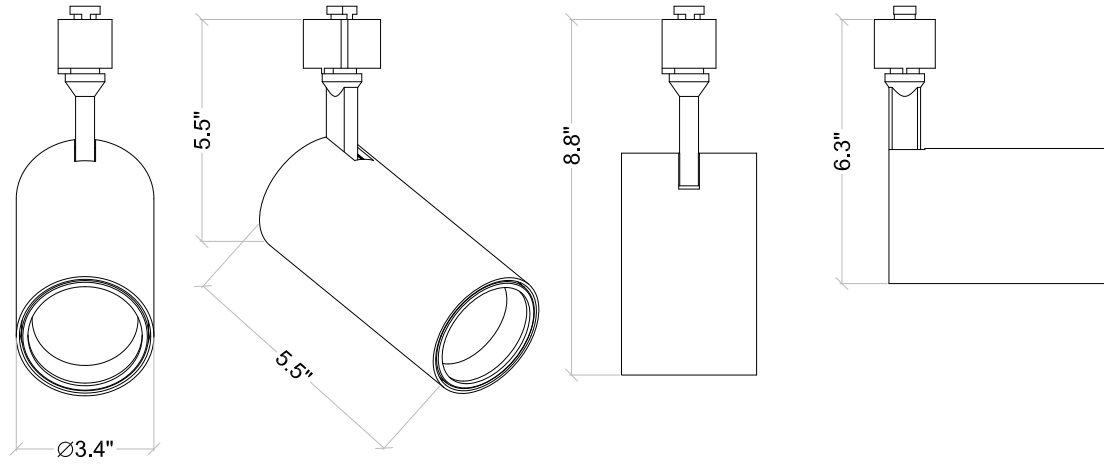

## Photometric Data

Data shown is measured for 30K light source. Multiply lumens, CBCP, FC and Lux by the following adjustment factors for other light sources

Light Source	27K	30K	35KT	40K	50K
Adjustment factors	0.88	1.00	1.03	1.05	1.10

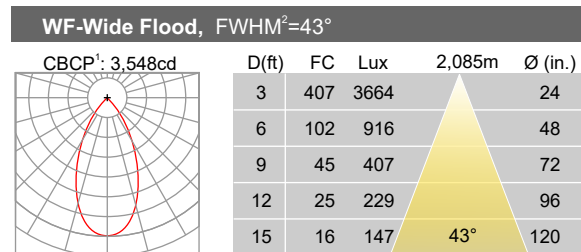
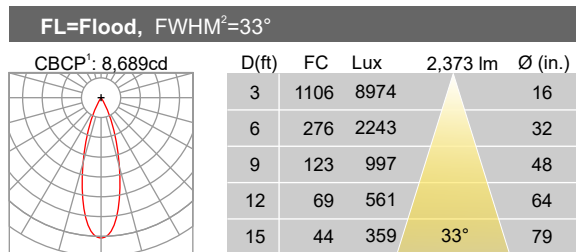
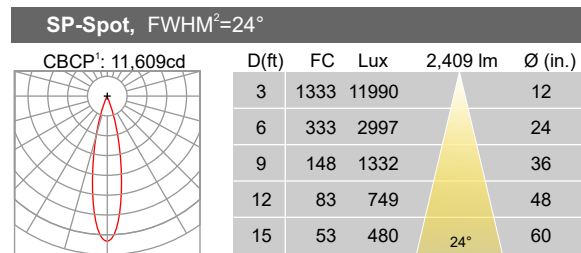
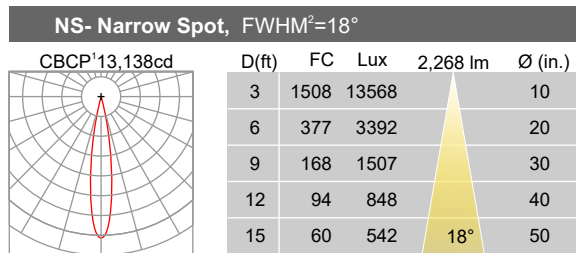

<sup>1</sup> CBCP: Centre Beam Candlepower

<sup>2</sup> FWHM: Full Width Half Maximum Angle

# CANISTER T638 30W Large Track Head

## Colorimetric, TM30-15

2700K.

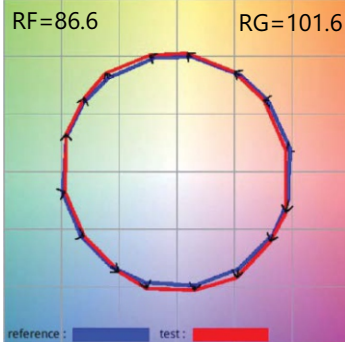

CRI>90 Duv<-0.001

3000K

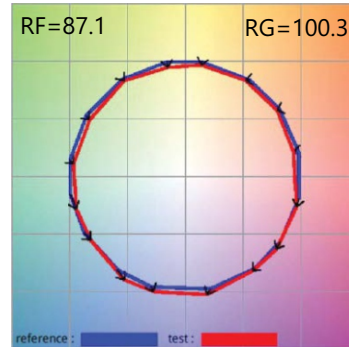

CRI>90 Duv<-0.001

3500K

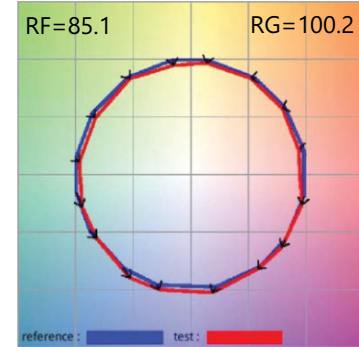

CRI>90 Duv < -0.001

4000K.

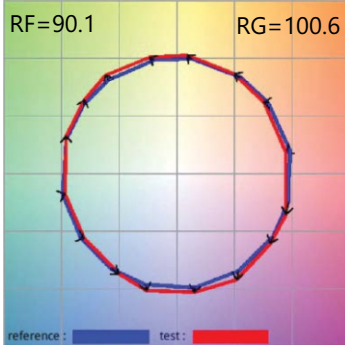

CRI>90 Duv<-0.001

5000K

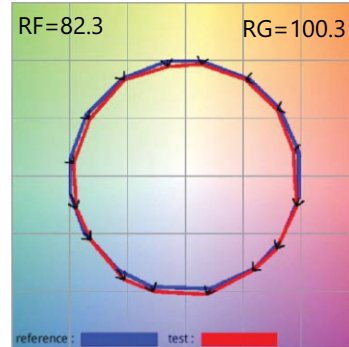

CRI>90 Duv<-0.001

## Compatible Dimmers

Lutron®		Leviton®	Cooper®
S-603PG	SELV-300P	IPI06-1LZ	DLC03P
DVCL-153P	TG-600P	6631-2	DAL06P
DV-600P	LG-600P	VPE06	SLC03P
TGCL-153P	CT-103P	6683-IW	
S-600P	MAELV-600	6161	
DVEL-303P	FAELV-500	6633-P	

## Accessory



Honeycomb Louver